

ADJUSTABLE TABLE LEG

RTL-KUS

Discontinued

This item will be discontinued when the current stock is run out.

**Features**

- Height can easily be adjusted by hand.
- Recommended for workbenches. Also recommended for tables that promote accessibility and universal design.
- Mark on inner pipe is an indicator to help with height alignment.
- Recommended to use 2 - 4 pcs on surfaces over 900 mm so that surface is flat and not angled after height adjustment.
- Please contact us for options about changes to stroke, height and colour. For changes to diameter, shape or load capacity, please consult us.
- Models that can be supported on a single leg with a base or have separate height fixing functions are available by special order.

Remarks

- The table surface will tilt during height adjustment.
- The tabletop must be supported with hands while the height is being lowered.
- The space between the legs should be 900 mm or less.
- In cases where the distance is large, there is a possibility that loads that place unequal weights on different sides can cause the table to become unstable.

For these cases, please reinforce the table legs and increase their rigidity.

Others

- Change to stroke, pitch and pipe colour is possible. For diameter, shape and load capacity change, please consult us.
- Oil adhered to the inner pipe will decrease the friction at the time of descent. Besides, if the lower movement is not so smooth, wipe the inner pipe gently with a cloth containing a little industrial lubricating oil. Please gently wipe excessive oil (if any) with a clean cloth. Do not use oil that will react with urethane. This is because the inner pipe may come in contact with the urethane O-ring on the inside of the pipe. Also, inner pipe can be in contact with urethane O-ring inside of the product. Please use oil which is not affect urethane.

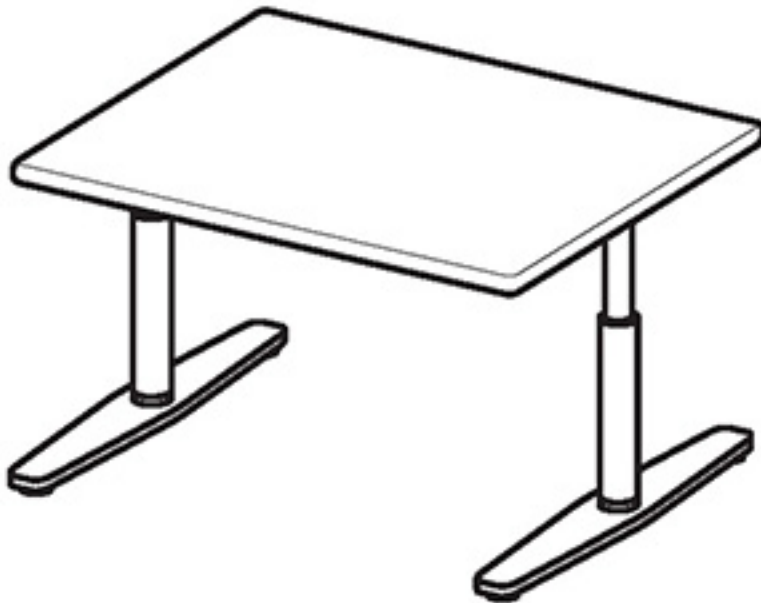
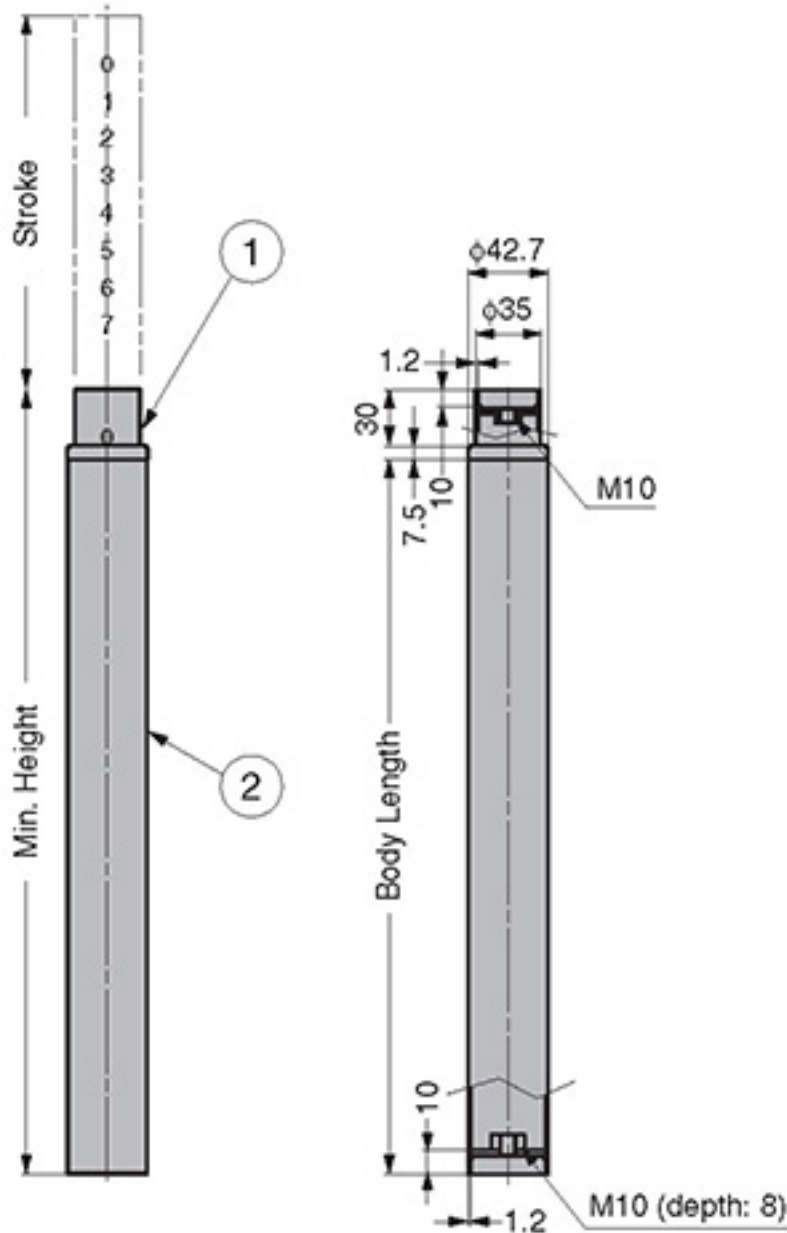
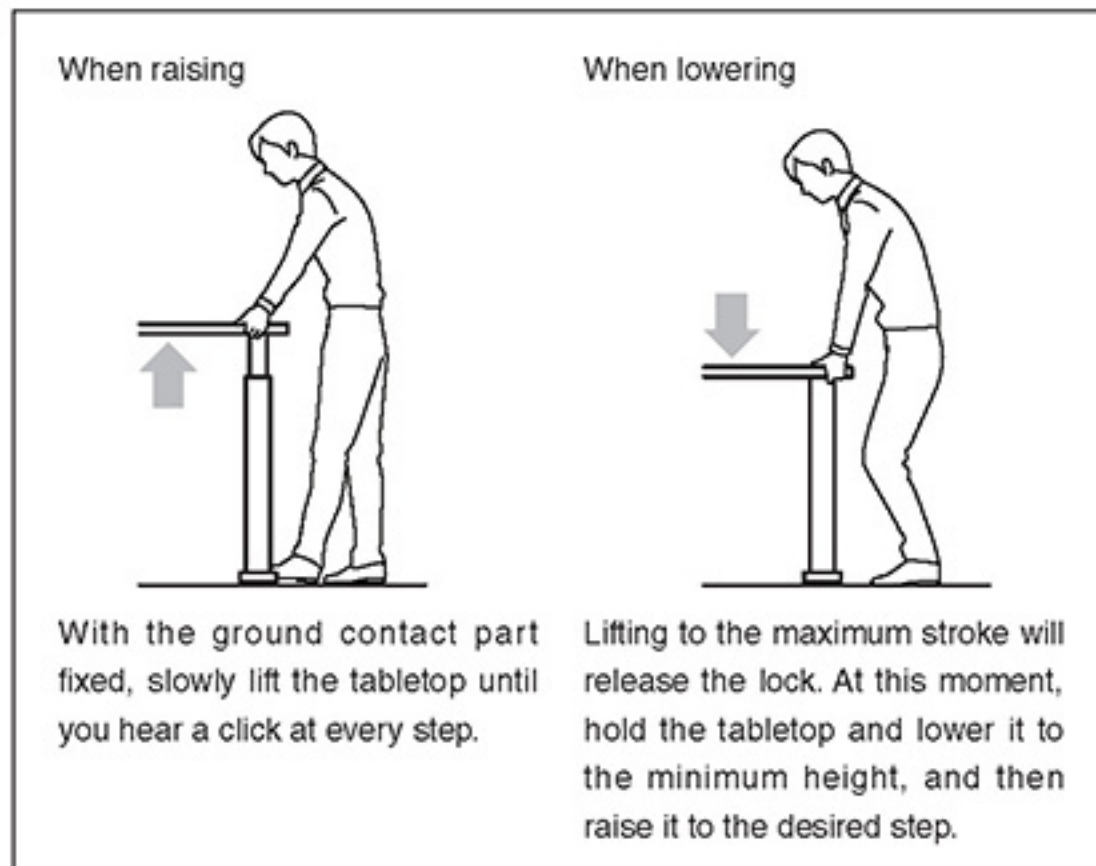
Application Example**How to Raise and Lower**

No.	Part Name	Material	Finish / Colour
①	Inner Pipe	Steel	Chrome
②	Body	Steel	Paint/Black
③	Top of the body	Polyamide(PA)	Black

CAD	Item Code	Item Name	Min. Height	Stroke	Body Length	Adjustable Pitch	Adjustable Steps	Load Capacity N/pc	Load Capacity kgf/pc	Weight (kg)	Box (pcs)	Carton (pcs)
3D	200-035-569	RTL-KUS-5	320	100	282.5	20	5	400	40	0.86	-	-
3D	200-035-570	RTL-KUS-10	420	200	382.5		10			1.1	-	-
3D	200-035-571	RTL-KUS-15	520	300	482.5		15			1.35	-	-

※ Limited stock available. Please contact your vender.